

PART NO. 002-01-08075

REVISIONS			
LTR	DESCRIPTION	Drawing	DATE
A	NEW	LUCK	02/06/15

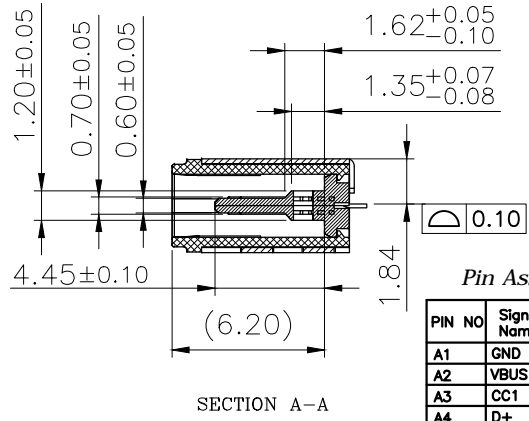
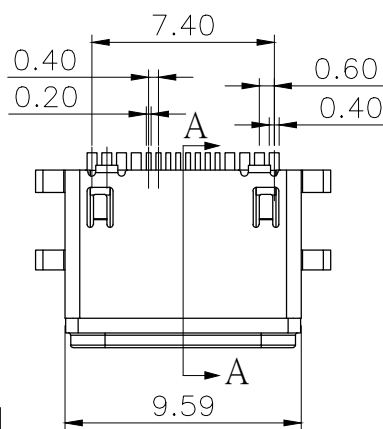

Pin Assignments

PIN NO	Signal Name	PIN NO	Signal Name
A1	GND	B8	GND
A2	VBUS	B7	VBUS
A3	CC1	B6	SUB2
A4	D+	B5	D-
A5	D-	B4	D+
A6	SUB1	B3	CC2
A7	VBUS	B2	VBUS
A8	GND	B1	GND

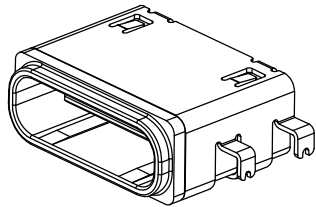
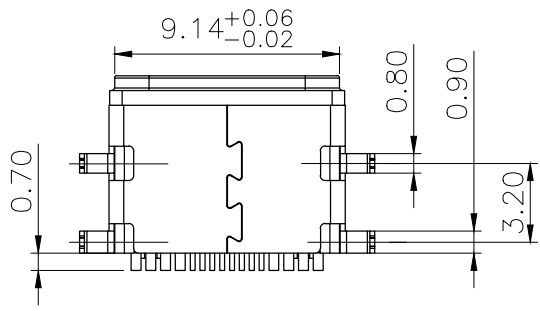
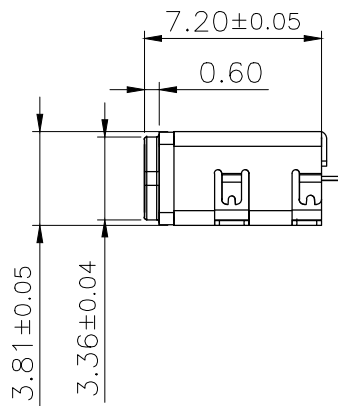
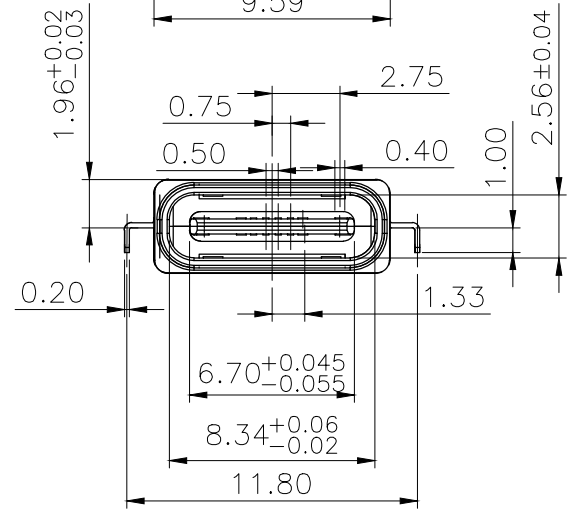
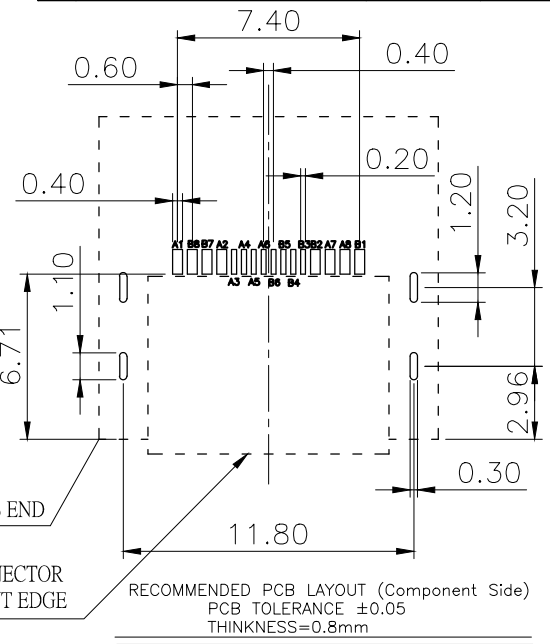

- NOTES:
- MATERIAL:
HOUSING:LCP+30%GF,UL94 V-0,COLOR:BLACK.
CONTACT:CU02 T=0.15±0.01mm
SHELL:C2680R-H T=0.20±0.01mm
 - PLATING:
CONTACT:50U"MIN NICKEL UNDERPLATING OVER ALL.
GOLD PLATED ON THE CONTACT AREA.
MISTY TIN PLATED ON THE SOLDER AREA.
GOLD SPECIFICATION:a,G/F;
SHELL:50U"MIN NICKEL UNDERPLATING OVER ALL.
MISTY TIN PLATED OVER ALL.
 - ELECTRONICAL SPECIFICATION:
CONTACT CURRENT RATING:5.0A FOR VBUS AND GND CONTACTS.
1.25A FOR ALL VCONN PIN.
0.25A FOR ALL OTHERS CONTACTS.
CONTACT RESISTANCE:40 MILLIOHMS MAX.
INSULATION RESISTANCE:100 MEGOHMS MIN.
DIELECTRIC WITHSTANDING VOLTAGE:100V AC.
 - MECHANICAL CHARACTERISTICS:
INSERTION FORCE:2.04kg.(20N) MAX
EXTRACTION FORCE:0.816kg.(8N) MIN
DURABILITY:10000 CYCLES MIN
5.OPERATING TEMPERATURE:-25°C~+85°C

DIMENSION ARE MILLIMETERS TOLERANCES ARE : DECIMALS .X ± 0.25 .XX ± 0.20 ANGLE: X ± 1°	APPROVALS		DATE	TITLE: USBTYPE C 母座 16PIN 沉板置中(SMT) L=7.20 内凹接口
	DRAWN	LUCK	02/06/15	
	CHECKED			
	APPROVALS			SIZE SCALE : 1 : 1
				DRAWING NO. 001006
				REV. A

NO	DESCRIPTION	QTY	UNIT	DO NOT SCALE DRAWING	ID NO	XXXXXXXXXX	SHEET	1 OF 1
----	-------------	-----	------	----------------------	-------	------------	-------	--------